



THE NEW SYMBOL OF INNOVATION

Three Door Sandwich Preparation Unit



S3BRR-18S

70.5" wide, 18 pans

Stainless steel interior & exterior standard!
 Factory-installed casters!
 The most durable condiment lid in the industry!

STANDARD FEATURES:

- Capillary tube
- Rear-Mounted Compressor & Evaporator Coil
- CFC-free R-134a Refrigerant
- Evaporative Condensate Pan
- Thermostatic Control
- Clear, 4" Deep Polycarbonate Food Pans
- 8' Cord & Plug
- 5" Casters - factory installed (front two locking)
- Foamed-in-place Polyurethane Insulation
- 1 Epoxy-Coated Wire Shelf per door
- Snap-In Magnetic Door Gaskets
- Stainless Steel Catch Tray under pans
- 12" Removable Cutting Board
- Fully-Recessed Door Handles with 90° hold-open feature
- Fully Covered Interior Corners
- 1" Insulated Condiment Lid
- Assembled in the USA

MATERIALS:

INTERIOR: 304 series stainless steel interior for durability and appearance.
 Epoxy-coated wire shelves.

EXTERIOR: 16 gauge, 304 series stainless steel top.
 304 series stainless steel cabinet, doors, and lid.

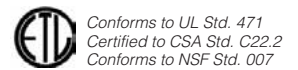

DIMENSIONAL DATA:

Model No.	L	D	H	Doors	Cu.Ft.	Pans	Shelves	H/P	Volt	Amp.	NEMA	Shipping Wt.
S1BRR-06S	27.5	29.5	42.5	1	6	8	1	1/5	115/60/1	3.9	5-20P	260
S2BRR-12S	47.0	29.5	42.5	2	12	12	2	1/3	115/60/1	8.0	5-20P	360
S3BRR-18S	70.5	29.5	42.5	3	18	18	3	1/2	115/60/1	9.1	5-20P	510
M1P-2712	27.5	34.0	46.0	1	6	12	1	1/4	115/60/1	5.2	5-20P	270
M2P-4818	47.0	34.0	46.0	2	12	18	2	1/3	115/60/1	6.3	5-20P	370
M3P-7127	70.5	34.0	46.0	3	18	27	3	1/2	115/60/1	7.4	5-20P	520



Refrigeration Equipment Manufacturer

Sandwich Prep Unit

S3BRR-18S

Description: Three solid door sandwich prep unit, 18 cu. ft

Features & Benefits

Stainless steel interior and exterior for greater durability, construction and appearance.

Self-contained **rear-mounted refrigeration** with high humidity coated fin coil evaporator.

- Holds 33° F to 41° F for refrigerator

2.5" thick, foamed-in-place polyurethane high density insulation.

Eighteen poly-carbonate, 1/6 size pans.

Factory-installed 5" casters standard for easy mobility and installation.

Twelve inch full length removable cutting board. 16 gauge, 300 series stainless steel top.

Self-closing doors with 90 degree hold-open feature and fully-recessed handles.

Evaporative condensate pan - no floor drain required!

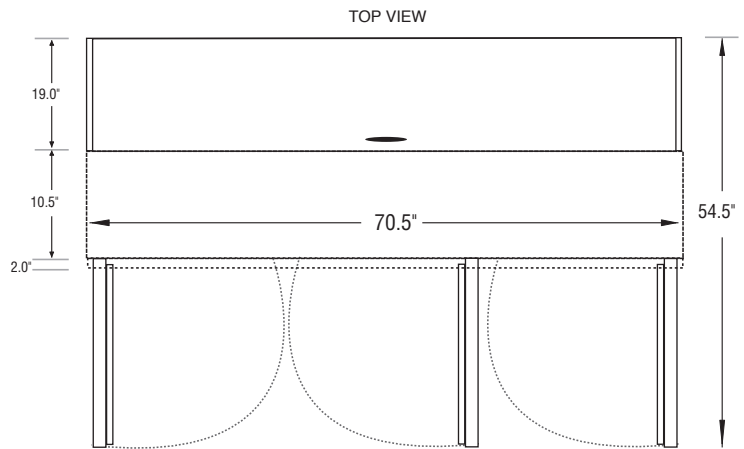
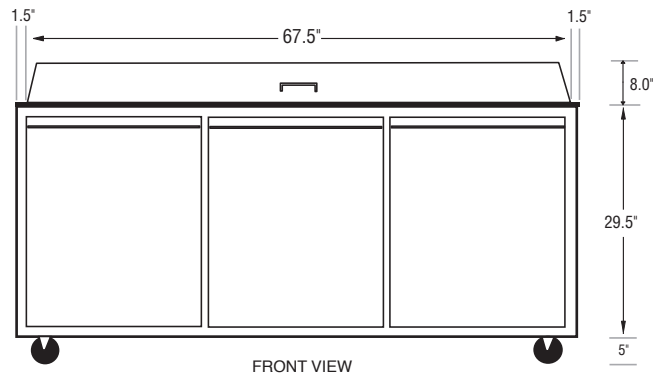
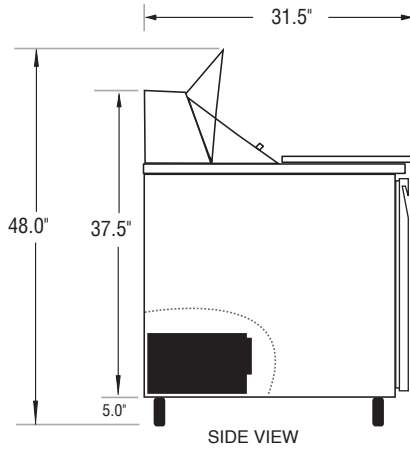

PAN CONFIGURATION



OPTIONS

- Extra Interior Shelves Qty. _____
- Other Specify _____

General Information

Cubic Ft.: 18

Shelf Size: 17" x 21.5"

Pans: 18

#Shelves: 3

Exterior: Stainless

Unit Weight: 360 lbs.

Interior: Stainless

Ship Weight: 510 lbs.

Technical Data

Refrigerant: R-134a

Volts: 115

Start Amps: 10.0

#Compressors: 1

Run Amps: 9.1

Cord Length: 104 in.

Horsepower: 1/2