

PROFESSIONAL QUALITY COOKING EQUIPMENT

OWNER'S MANUAL FOR PROFESSIONAL SERIES FRYERS

MODEL NUMBERS:

AF25, AF25/25, AF35/40, AF35/50,
AF35/50RM, AF50/25, AF75, AFDS



DESIGN



CLASS



FUNCTION

AF Series Fryers Owner's Manual

Installation, Operation and Maintenance Instructions



FOR YOUR SAFETY

FOR YOUR SAFETY!
Do not store or use gasoline or other flammable vapors or liquids in the vicinity of this or any other appliance.

FOR YOUR SAFETY



WARNING!
Improper installation, adjustment, alteration, service or maintenance can cause property damage, injury or death and will void warranty. Read the installation, operating and maintenance instructions thoroughly before installing or servicing this equipment.



IMPORTANT SERVICE NOTICE!
Using any part other than genuine American Range factory supplied parts relieves the manufacturer of all liability. American Range reserves the right to change product design and specifications without notice. Such revisions do not entitle the buyer to corresponding changes, improvements, additions or replacements for the previously purchased equipment.

Instructions to be followed in the event the user smells gas should be posted in a prominent location. This information should be obtained by consulting the local gas supplier.

RETAIN THIS MANUAL FOR FUTURE REFERENCE.

This equipment is design engineered for commercial use only.

Model Number: _____
Serial Number: _____
Purchase Date: _____
Installed By: _____ Install Date: _____
Gas Type: _____
Electrical Information: _____





PROFESSIONAL QUALITY COOKING EQUIPMENT

To Our Most Valued Customer:

Congratulations on your purchase of an American Range product. We hope you will enjoy the design, manufactured quality, innovative features and cooking performance of this product – it represents our continuing dedication to satisfying the most demanding needs of customers like you.

Please read this manual and become familiar with important safety information about how to install and set-up the unit, basic operating instructions, and how to maintain that just-like-brand-new appearance and performance - over years of day-to-day use.

If you should encounter any sort of problem, turn to the section of the manual entitled, "Troubleshooting" – for a quick solution or guidance regarding the next step required to get back to tip-top condition.

Thank you for choosing an American Range product for your kitchen. As you can expect, this appliance is designed for years of reliable service. If you have any questions or comments, please contact the dealer from whom you purchased the unit, or contact American Range Customer Service via email: info@americanrange.com at www.americanrange.com, or call 888.753.9898.

Sincerely,

Shane Demirjian

President, American Range Corporation



Table of Contents

GENERAL 1-3

- General Information 1
- About This Manual 2
- Shipping Damage Claim Procedure 3
- Rating Plate 3
- Clearances 3

INSTALLATION 4-6

- Gas Utility Connections-Standards & Codes 4
- Instructions 4
- Fryers with Casters 4
- Wiring Diagram 5
- Models and Parts Identification 6
- Installation Checklist 7

OPERATING 8-9

- Before Turning Burner On 8
- Lighting 8
- Frying with Shortening 8
- Cleaning 9

EXPLODED VIEW DRAWINGS/PARTS LISTS 10-17

- AF-25 10-11
- AF-35/50 12-13
- AF-45 14-15
- AF-75 16-17

TROUBLESHOOTING 18

WARNING

If the information in this manual is not followed exactly, a fire or explosion may result causing damage, personal injury or death.

- INSTALLATION AND SERVICE MUST BE PERFORMED BY A CERTIFIED / LICENSED INSTALLER, SERVICE AGENCY OR THE GAS SUPPLIER
- Do not store or use gasoline or other flammable vapors or liquids in the vicinity of this or any other appliance.

- WHAT TO DO IF YOU SMELL GAS
 - Do not try to light any appliance.
 - Do not touch any electrical switch, do not use any phone in your building.
 - Immediately call your gas company. Follow the gas supplier instructions.
 - If you cannot reach your gas supplier, call the Fire Department.

WARRANTY REQUIREMENT

For reliable operation and for your own safety, this professional cooking equipment must be installed by a certified/licensed contractor.

Failure to comply will void any written or implied warranty.

Should the equipment require service during the standard warranty period, the receipt proving certified installation must be made available to American Range for verification.

If installation was not performed by a certified/licensed contractor be prepared to submit a major credit card for payment for proper installation.

- Please observe all local and national codes and ordinances.
- Do not remove any permanent warning labels or plates from this product.
- Consumers should retain these instructions for local inspectors and for future use.

ABOUT THIS MANUAL

The Use and Care Manual is divided into several sections:

The Safety Section informs you about significant safety precautions when installing and operating your new fryer. This is a must read section of the manual.

Quick Start and Installation Section describes how to unpack the unit, what to save and what to discard, installation dimensions, gas and electrical connections and how to identify the primary parts of the product so you can better understand what's going on "under the hood".

How to Use Your Product shows you how to light the pilot and set frying temperatures.

The Care and Maintenance and Troubleshooting and Service Sections discuss how to keep your product in good operating condition, how to identify what might be going wrong with the unit, and how to communicate your observations with authorized field service technicians.

Before using your appliance, please read this manual paying special attention to the important safety instructions located in the next several pages.



This is the SAFETY ALERT SYMBOL. This symbol alerts you to hazards which will result in severe injury or death.



DANGER

Hazards or unsafe practices which will result in severe personal injury or death.



WARNING

Hazards or unsafe practices which may result in severe personal injury or death.



CAUTION

Hazards or unsafe practices which may result in minor personal injury or property damage.

CALIFORNIA PROPOSITION 65 WARNING

The burning of gas cooking fuel generates some by-products which are on the list of substances known by the State of California to cause cancer or reproductive harm. California law requires businesses to warn customers of potential exposure to such substances. To minimize exposure to these substances, always operate this unit according to the Owners Manual, ensuring you provide proper ventilation when cooking with gas.

IMPORTANT - PLEASE READ AND FOLLOW!

- Before beginning, please read all the instructions carefully.
 - **DO NOT** remove permanently affixed labels, warnings, or plates from product. This will void the warranty.
 - All local and national codes and ordinances must be observed; installation must conform with local codes.
 - The Installer must leave these instructions with the consumer who should retain for local inspector's use and for future reference.
 - Installation and service must be performed by a certified / licensed installer, service agency or gas supplier.
- Your safety and the safety of others is very important. We have provided many important safety messages in this manual and on your appliance. Always read and obey all safety messages.

SHIPPING DAMAGE CLAIM PROCEDURE

The equipment is crafted and inspected carefully by skilled personnel before leaving the factory. The transportation company assumes full responsibility for the safe delivery upon acceptance of the equipment.

If you receive a damaged product, immediately contact your delivery company, your dealer, your builder or installer. Do not install or attempt to operate a damaged appliance.

1. Note any visible loss or damage on the freight bill or express delivery and have the note signed by the person making the delivery.
2. File claim for damages immediately regardless of the extent of damages.
3. For damage noticed after unpacking (concealed loss or damage), notify the transportation company immediately and file a "Concealed Damage" claim with them. This should be done within fifteen (15) days from the date that delivery is made to you. Retain the shipping container for inspection.

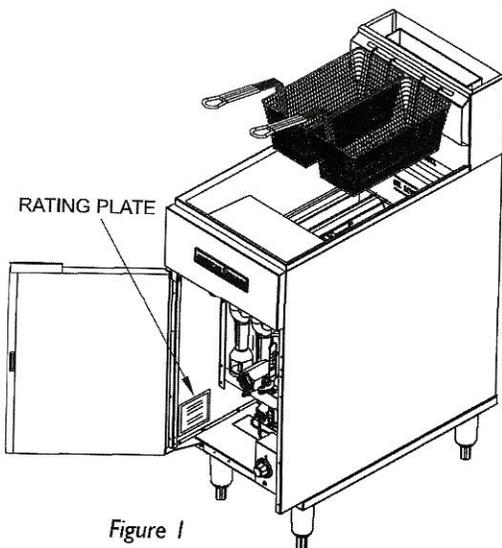

Figure 1

RATING PLATE - The location of the rating plate is shown in *Figure 1*. The information on the rating plate defines the model, serial number, gas type (natural or liquid propane), operating pressures and burner BTU ratings. Keep this information for future reference. It is essential for proper identification of the unit when requesting additional information or factory support.

AMERICAN RANGE		NSF		ETL		ETL	
13592 DESMOND ST., PACOIMA, CA 91331		Intertek Intertek		3013256			
MODEL: AF-45	SERIAL NO. 999999-CO8999						
GAS TYPE: NAT	MAN. PRESS: 4.0	IN. W.C.	TANK ID#2				
INPUT-BTU/HOUR/BURNER	45,000		CLEARANCES		NON-COMB. COMB.		
		BACK 0" 6"		SIDES 0" 6"			
SUITABLE FOR INSTALLATION ON COMBUSTIBLE FLOORS USING 6" ADJ. LEGS OR CASTERS. INTENDED FOR OTHER THAN HOUSEHOLD USE. ANSI Z83.11a/CSA 1.8a-2007 Food Service Equipment							

Rating Plate



WARNING

Appliances must be connected only to the type of gas identified on the rating plate.

CLEARANCES - The appliance must be kept free and clear of all combustible materials. This unit is designed and certified for the following installation only:

	CLEARANCES	
	NON-COMBUSTIBLE	COMBUSTIBLE
Sides	0"	6"
Rear	0"	6"
Floor	0"	6"

Installation on non-combustible floor shall be with factory supplied legs or casters.

INSTALLATION

INSTALLATION - GAS UTILITY CONNECTIONS-STANDARDS AND CODES



WARNING

The installation instructions contained here are for the use of qualified installation and service personnel only. Installation or service by other than certified / licensed personnel will void the warranty and will result in damage to the fryer and/or injury to the operator.

Qualified installation personnel, licensed and bonded, must be experienced in such work, familiar with all precautions required and have complied with all requirements of state or local authorities having jurisdiction.

The ventilation of these fryers should be in accordance with local codes. In absence of local codes, refer to the national ventilation code titled, Standard for the Installation of Equipment for the Removal of Smoke and Grease Laden Vapors from Commercial Cooking Equipment, NFPA-96-Latest Edition.

The appliance is to be installed with a check valve in accordance with applicable federal, province and local codes.

GENERAL EXPORT INSTALLATIONS - Installation must conform to Local and National Standards. Local installation codes and/or requirements may vary. If you have any questions regarding the proper installation or operation of your American Range Fryer, please contact your local distributor. If you do not have a local distributor, contact American Range Corporation at 1.888.753.9898 or visit us at www.americanrange.com

INSTRUCTIONS

The area around the appliance must be kept free and clear of combustibles such as solvents, cleaning liquid, broom, rags, etc.

All threaded joints of the appliance piping must be sealed with a compound that is resistant to the action of natural gas or liquefied petroleum gases and the joint connection checked for gas leaks using a soapy water solution before lighting the pilots.

Proper clearances must be provided at the front of the appliance for servicing and proper operation.

For proper combustion and ventilation provisions shall be incorporated in the design of the kitchen, to ensure adequate supply of fresh air and adequate clearance for air openings into the combustion chamber.

For proper operation of the appliance, do not obstruct the flow of combustion and ventilation air.

A manual gas shut-off valve shall be installed when the appliance is connected to the gas supply.

The rating plate is located inside of the left side panel.

The connecting wiring diagram is located on the lower inside of the left side panel.

The installation must conform with local codes, or in the absence of local codes, with the National Fuel Gas Code, ANSI Z223.1/NFPA54, or the Natural and Propane Gas Installation Code, CSA B149.1, as applicable, including:

1. The appliance and its individual shut-off valve must be disconnected from the gas supply piping system during any pressure testing of that system at test pressure in excess of 1/2 PSI (3.5KPa).
2. The appliance must be isolated from the gas supply piping system by closing its individually manual shut-off valve during any pressure testing of the gas supply piping system at test pressure equal to or less than 1/2 PSI (3.5KPa).

The gas supply line must be at least 3/4" ID (inside dimensions) size as the gas inlet of the appliance.

FRYERS WITH CASTERS - When this appliance is installed with casters it must be installed with a connector that complies with the standard for connectors for movable gas appliances, ANSI Z21.69 CSA.16, and a quick-disconnect device that complies with the standard for quick-disconnect devices for use with gas fuel, ANSI Z21.41 CSA6.9. Adequate means must be provided to limit the movement of the appliance without depending on the connector and the quick-disconnect device or its associated piping to limit the appliance movement. The restraining device may be attached to the rear panel of the appliance.



WARNING

When installing the pressure regulator - remember it can only handle 1/2 PSI. In every LPG installation, you have high source pressures, ranging from 20 PSI to 100 PSI. If the high pressure gas line from the LPG tank is directly connected to the unit without the proper step-down regulator, it will rupture the diaphragm in the valve, rendering it useless.

MODEL AND PARTS IDENTIFICATION

DESCRIPTION	AF SERIES FRYERS							
	AF25	AF25/25	AF35/40	AF35/50	AF35/50RM	AF25/50	AF75	AFDS
Basket Hanger	1	2	1	1	1	2	1	0
Baskets	1	2	2	2	2	3	2	0
Rack/Screen	1	2	1	1	1	2	1	1
Burners	2	4	2	3	3	5	4	
Drain Extension Pipe	1	2	1	1	1	2	1	0
Legs	2	4	4	4	4	4	4	4
Regis. Card	1	1	1	1	1	1	1	1
U&C Manual	1	1	1	1	1	1	1	1

INSTALLATION CHECKLIST

This checklist has been developed to assure proper installation of your oven.
 To validate warranty, you must mail, e-mail or fax this form and a copy of your receipt to:
AMERICAN RANGE CUSTOMER SERVICE, 13592 DESMOND STREET, PACOIMA, CA 91331
 service@americanrange.com
 818.897.8839 FAX

Street: _____

Purchase Date: _____

City, State, Zip Code: _____

Installation Date: _____

E-mail: _____

Installer's Name: _____

Telephone: _____

Company: _____

Dealer: _____

Telephone: _____

CHECK ALL THAT APPLY

Appearance and Aesthetics

- Exterior
- Top section
- Oven interior

Installation

- Read User Manual
- Review Safety Instructions
- Proximity to cabinets
- Backguard in place
- Level
- Ventilation system

Ignition

- Top Burners
- Griddle
- Char Broiler
- Oven Burner
- Infrared Broiler

Controls

- Burner Knobs
- Thermostats
- Char Broiler
- Convection Oven Fan & Switch
- Oven Light Switch

Electrical Connection

- Correct voltage
- Grounded outlet
- Polarized outlet
- No GFCI

Gas Connection

- Verify fuel: Natural -or- LP
- Gas shut-off present and accessible
- Gas Supply line properly sized
- Gas Supply pressure checked
- Operating pressure checked
- All connections checked for leaks

Flame Adjustment

- Top Burners
- Griddle
- Char Broiler
- Oven Burner
- Infrared Broiler

Oven Door

- Alignment
- Door Seal
- Hinges

Air/Gas Mixture

- Top Burners
- Griddle
- Char Broiler
- Oven Burner
- Infrared Broiler

Valve Operation

- Top Burners
- Griddle
- Char Broiler
- Oven Burner
- Infrared Broiler

Customer Copy



OPERATING INSTRUCTIONS



WARNING

The installation instructions contained here are for the use of qualified installation and service personnel only. Installation or service by other than certified / licensed personnel will void the warranty and will result in damage to the oven and/or injury to the operator.

BEFORE TURNING THE BURNER ON

1. Fill the vessel with a liquid oil up to the "Level" marking.
2. Do not operate fryer without oil in the vessel.
3. Do not overfill the vessel.

LIGHTING

1. Before attempting to light this appliance, the door if so equipped, shall be open.
2. Turn the appliance manual gas shut-off valve to the OFF position.
3. Turn the combination gas control knob to the OFF position.
4. Turn the thermostat control to the OFF position.
5. Wait 5 minutes.
6. Turn the appliance manual gas shut-off valve to the ON position.
7. Turn the combination gas control knob to the PILOT position.
8. Light the pilot with a match while depressing and holding the combination gas control knob until the pilot remains lit upon releasing the gas control knob.
9. Turn the combination gas control knob to the ON position.
10. Turn the thermostat control knob to the desired temperature to turn burners ON.
11. Ensure that the door is closed during operation.
12. For complete shut-down, repeat steps 2, 3, and 4.

LIGHTING INSTRUCTION is located on the lower inside of the left side panel.

FRYING WITH SHORTENING

The type of fat that you use in frying influences many qualities of the finished product such as flavor, texture, shelf life and nutritional attributes. How often you use the fryer – and the temperature that you cook at – will determine how long the fryer oil can be used – most can last up to 100 hours.

Depending on the menu and local eating patterns, fryers will usually be operated at full capacity for a few hours a day, intermittently for a few hours and be idle the remainder of the time. Operating a fryer on an intermittent basis is the primary reason that frying oil must be discarded and replaced periodically. During the idle and low production periods, the oil is subjected to thermal and oxidative stress more than it is during the active frying process. If fryers were operated without interruption and oil was filtered regularly, frying oil would rarely need to be discarded.

Oil and shortening are two types of fat that are typically used in commercial deep fryers. Shortening comes in tubs or bricks and quickly melts down to a liquid for frying purposes – however, it is not used as much now, because it is high in calories and fat. Healthier fry oils like vegetable, canola, and the like are more commonly used in restaurants.

When deep fat frying, remember to never operate the fryer with the tank empty. The burners used in fryers are very powerful – mainly to quickly heat the oil and to help recover heat during the cooking process. This power can damage a fryer tank, because the metal of the tank – which is usually cooled by the oil – expands and this expansion could stress and fracture the welds.

So, the tank must be filled with water or cooking oil/shortening before lighting the burners. The bottom line is that failure to do so will damage the tank and may even cause a fire.

To deep fry with shortening, always start with an empty and/or cleaned-out tank and melt the shortening on the stove – carefully pouring it into the tank. That way, you can be sure the shortening is in full contact with the fryer tank metal – eliminating the potential of weld fracture from dry firing.

OPERATING INSTRUCTIONS

WEEKLY CLEANING

1. Shut down the fryer by turning the thermostat and pilot valve to the OFF position.
2. Disconnect the restraining device before moving the appliance for cleaning and servicing.
3. Drain the fryer into a filtered pan or steel container. Flush out sediment at the bottom of fryer with liquid oil.
4. Close the drain valve and fill the vessel with a mixture of boil-out solution and water.
5. Relight the pilot and turn on the burners.
6. When the solution starts to boil, turn off the thermostat and let the vessel soak to soften deposits and/or carbon spots. Approximately one hour.
7. Drain off the solution, scrub the insides with brush and rinse thoroughly.
8. Repeat steps 4-7 if necessary.
9. Wipe dry with soft towels and refill with oil/shortening.
10. Re-connect the restraining device after returning the appliance to its originally installed position.

STAINLESS STEEL PARTS - Do not use steel wool, abrasive cloths, cleaners or powders to clean Stainless Steel surfaces. All Stainless Steel parts should be wiped regularly with hot soapy water during the day and a Stainless Steel cleaner at end of the day. To remove encrusted materials, soak in hot water to loosen the material - then use a wood or nylon scraper.



WARNING

All water must be removed before adding oil or shortening. Not doing so can result in splattering of hot oil causing severe burns and burn hazard.



WARNING

DO NOT DRY-FIRE; operating the unit without liquid is an extreme fire hazard and will cause irreparable damage such as gas leaks, scorched surfaces and burnt components.



WARNING

1. Do not dry fire the fryer; this will cause a leak. Dry firing is typically done after cleaning when the end user wants to dry out the tank the "easy" way. It is a major cause of tank damage in the industry.
2. Do not drain the oil while it's hot; wait until it cools before emptying. Rapid change in temperature causes stress fractures and tears at the seams.
3. Do not use acidic cleaners; use only boil-out solution. Acid can cause erosion to metal and in due time can cause a leak in the tank.
4. Solid shortening must be liquefied before filling the tank. The tank walls must have liquid against it in order to transfer heat and avoid overheating and stressing the metal to the point of a tear.
5. Do not rinse off a hot tank with cold water. Always allow it to cool first.
6. Do not use sharp tools to clean the fryer.
7. Keep your tank clean. Check for debris buildup at the bottom of the tank, and never allow too much build-up to occur.

TROUBLESHOOTING GUIDE

POSSIBLE CAUSE	SUGGESTED ACTION
SYMPTOM: Burners do not come on.	
Unit is not connected to gas service	Visually check unit is plumbed to gas
Pilot is not burning	Light pilot
Thermostat is set to very low temperature	Set temperature to desired value
SYMPTOM: Fryer does not reach selected temperature.	
Unit may not have been operating long enough	Unit preheats to 350°F in about ten minutes
Thermostat may be defective	Unit will require service
Too little gas pressure, dirty gas line	Call for authorized service
SYMPTOM: General frying problems.	
Temperature too low or too high	Set unit to recommended temperature for foods being fried.
Thermostat out of calibration	Unit will require service



WARNING

Always disconnect the gas service before cleaning or servicing the fryer.

WARRANTY REQUIREMENT

For reliable operation and for your own safety, this professional cooking equipment must be installed by a certified/licensed contractor.

Failure to comply will void any written or implied warranty.

Should the equipment require service during the standard warranty period, the receipt proving certified installation must be made available to American Range for verification.

If installation was not performed by a certified/licensed contractor be prepared to submit a major credit card for payment for proper installation prior to service.

DESIGNED & BUILT IN USA
PROFESSIONAL COOKING EQUIPMENT

AMERICAN RANGE
QUALITY COOKING EQUIPMENT

13592 Desmond Street, Pacoima, CA 91331
818.897.0808 tel 888.753.9898 toll free
818.897.1670 fax
www.americanrange.com